

TOSHIBA

INSTALLATION MANUAL MANUEL D'INSTALLATION EINBAUANLEITUNG MANUALE DI INSTALLAZIONE MANUAL DE INSTALACIÓN ΟΔΗΓΙΕΣ ΕΓΚΑΤΑΣΤΑΣΗΣ MANUAL DE INSTALAÇÃO INSTALLATIEHANDLEIDING ИНСТРУКЦИЯ ПО УСТАНОВКЕ

AIR CONDITIONER (SPLIT TYPE)

CLIMATISEUR (TYPE SEPARÉ)
KLIMAGERÄT (GETEILTE AUSFÜHRUNG)
CONDIZIONATORE D'ARIA (TIPO SPLIT)
ACONDICIONADOR DE AIRE (TIPO SEPARADO)
ΚΛΙΜΑΤΙΣΤΙΚΗ ΜΟΝΑΔΑ (ΔΙΑΙΡΟΥΜΕΝΟΥ ΤΥΠΟΥ)
AR CONDICIONADO (TIPO SPLIT)
AIRCONDITIONER (TWEEDELIG TYPE)
ΚΟΝΔΙΤΙΟΝΕΡ (ΡΑΖΔΕΛΙΤΕΛ'ΝΥΙ ΤΙΠ)

For general public use
Pour utilisation grand public
Für allgemeine Verwendung
Per l'uso in generale
Para el uso público general
Για γενική δημόσια χρήση
Para utilização geral
Voor algemeen publiek gebruik
Для общего бытового использования

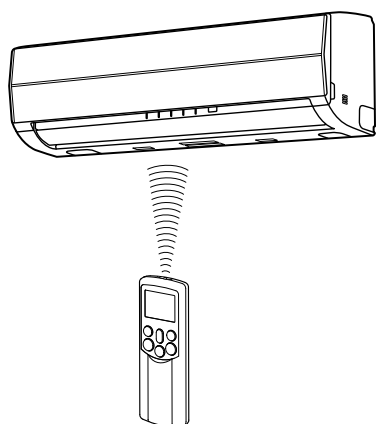

Indoor Unit Unité intérieure Innenraumgerät Unità interna Unidad interior Εσωτερική μονάδα Unidade interior Binnenapparaat Внутренний блок	Outdoor Unit Unité extérieure Außengerät Unità esterna Unidad exterior Εξωτερική μονάδα Unidade exterior Buitenapparaat Наружный блок
RAS-B10SKVP-E RAS-B13SKVP-E RAS-B16SKVP-E	RAS-10SAVP-E RAS-13SAVP-E RAS-16SAVP-E RAS-M14GAV-E RAS-M18GAV-E
RAS-M10SKCVP-E RAS-M13SKCVP-E RAS-M16SKCVP-E	RAS-M14GACV-E RAS-M18GACV-E

Please read this installation manual carefully before installing the air conditioner.

Veuillez lire attentivement ce manuel avant d'installer le climatiseur.

Lesen Sie diese Einbauanleitung sorgfältig durch, bevor Sie das Klimagerät installieren.

Prima di installare il condizionatore d'aria, si consiglia di leggere con attenzione il presente manuale di installazione.

Lea este manual de instalación atentamente antes de instalar el acondicionador de aire.

Παρακαλούμε διαβάστε αυτές τις οδηγίες εγκατάστασης προσεκτικά πριν εγκαταστήσετε την κλιματιστική μονάδα.

Leia atentamente este manual de instalação antes de instalar o ar condicionado.

Leest u vooral deze installatiehandleiding aandachtig door alvorens de airconditioner te installeren.

Перед установкой кондиционера прочитайте, пожалуйста, внимательно эту инструкцию по установке.

ENGLISH

FRANÇAIS

DEUTSCH

ITALIANO

ESPAÑOL

ΕΛΛΗΝΙΚΑ

PORTUGUÊS

NEDERLANDS

РУССКИЙ ЯЗЫК

CONTENTS/SOMMAIRE/INHALT/INDICE/ÍNDICE/ΠΕΡΙΕΧΟΜΕΝΑ/ ÍNDICE/INHOUD/СОДЕРЖАНИЕ

ENGLISH

1 SAFETY PRECAUTIONS	1
2 INSTALLATION DIAGRAM OF INDOOR AND OUTDOOR UNITS	3
3 OPTIONAL PARTS, ACCESSORIES AND TOOLS	4
4 INSTALLATION OF INDOOR UNIT	6
5 INSTALLATION OF OUTDOOR UNIT	12
6 TEST OPERATION	16

FRANÇAIS

1 MESURES DE SECURITE	1
2 SCHEMAS D'INSTALLATION DES UNITES INTERIEURE ET EXTERIEURE	3
3 PIECES EN OPTION, ACCESSOIRES ET OUTILS	4
4 INSTALLATION DE L'UNITE INTERIEURE	6
5 INSTALLATION DE L'UNITE EXTERIEURE	12
6 OPERATION D'ESSAI	16

DEUTSCH

1 SICHERHEITSVORKEHRUNGEN	1
2 EINBAUZEICHNUNGEN FÜR INNENRAUM- UND AUSSENGERÄT	3
3 SONDERTEILE, SONDERZUBEHÖR UND WERKZEUGE	4
4 INSTALLATION DES INNENRAUMGERÄTS	6
5 INSTALLATION DES AUSSENGERÄTS	12
6 PROBELAUF	16

ITALIANO

1 PRECAUZIONI PER LA SICUREZZA	1
2 SCHEMA DI INSTALLAZIONE DELL'UNITÀ INTERNA E DELL'UNITÀ ESTERNA	3
3 COMPONENTI OPZIONALI, ACCESSORI E STRUMENTI	4
4 INSTALLAZIONE DELL'UNITÀ INTERNA	6
5 INSTALLAZIONE DELL'UNITÀ ESTERNA	12
6 FUNZIONAMENTO DI PROVA	16

ESPAÑOL

1 PRECAUCIONES SOBRE SEGURIDAD	1
2 DIAGRAMA DE INSTALACIÓN DE LAS UNIDADES INTERIOR Y EXTERIOR	3
3 PARTES OPCIONALES, ACCESORIOS Y HERRAMIENTAS	4
4 INSTALACIÓN DE LA UNIDAD INTERIOR	6
5 INSTALACIÓN DE LA UNIDAD EXTERIOR	12
6 OPERACIÓN DE PRUEBA	16

ΕΛΛΗΝΙΚΑ

1 ΠΡΟΦΥΛΑΞΕΙΣ ΑΣΦΑΛΕΙΑΣ	1
2 ΕΙΚΟΝΕΣ ΕΓΚΑΤΑΣΤΑΣΗΣ ΕΣΩΤΕΡΙΚΗΣ ΚΑΙ ΕΞΩΤΕΡΙΚΗΣ ΜΟΝΑΔΑΣ	3
3 ΠΡΟΑΙΡΕΤΙΚΑ ΑΝΤΑΛΛΑΚΤΙΚΑ, ΕΞΑΡΤΗΜΑΤΑ ΚΑΙ ΕΡΓΑΛΕΙΑ	4
4 ΕΓΚΑΤΑΣΤΑΣΗ ΕΣΩΤΕΡΙΚΗΣ ΜΟΝΑΔΑΣ	6
5 ΕΓΚΑΤΑΣΤΑΣΗ ΕΞΩΤΕΡΙΚΗΣ ΜΟΝΑΔΑΣ	12
6 ΔΟΚΙΜΑΣΤΙΚΗ ΛΕΙΤΟΥΡΓΙΑ	16

PORTUGUÊS

1 PRECAUÇÕES DE SEGURANÇA	1
2 DIAGRAMA DE INSTALAÇÃO DAS UNIDADES INTERIOR E EXTERIOR	3
3 PEÇAS OPCIONAIS, ACESSÓRIOS E FERRAMENTAS	4
4 INSTALAÇÃO DA UNIDADE INTERIOR	6
5 INSTALAÇÃO DA UNIDADE EXTERIOR	12
6 TESTE	16

NEDERLANDS

1 VEILIGHEIDSVORSCHRIFTEN	1
2 INSTALLATIESCHEMA VOOR BINNEN- EN BUITENAPPARAAT	3
3 OPTIONELE ONDERDELEN, ACCESSOIRES EN GEREEDSCHAP	4
4 INSTALLEREN VAN HET BINNENAPPARAAT	6
5 INSTALLEREN VAN HET BUITENAPPARAAT	12
6 PROEFDRAAIEN	16

РУССКИЙ ЯЗЫК

1 МЕРЫ ПРЕДОСТОРОЖНОСТИ	1
2 ДИАГРАММА УСТАНОВКИ ВНУТРЕННЕГО И НАРУЖНОГО БЛОКОВ	3
3 ДОПОЛНИТЕЛЬНЫЕ ЧАСТИ, ПРИНАДЛЕЖНОСТИ И ИНСТРУМЕНТЫ	4
4 УСТАНОВКА ВНУТРЕННЕГО БЛОКА	6
5 УСТАНОВКА НАРУЖНОГО БЛОКА	12
6 ТЕСТОВАЯ ЭКСПЛУАТАЦИЯ	16

1 SAFETY PRECAUTIONS

ENGLISH

For general public use

Power supply cord of outdoor unit shall be 1.5 mm² (H07RN-F or 60245IEC66) polychloroprene sheathed flexible cord.

CAUTION

New Refrigerant Air Conditioner Installation

• **THIS AIR CONDITIONER ADOPTS THE NEW HFC REFRIGERANT (R410A) WHICH DOES NOT DESTROY OZONE LAYER.**

R410A refrigerant is apt to be affected by impurities such as water, oxidizing membrane, and oils because the working pressure of R410A refrigerant is approx. 1.6 times as that of refrigerant R22. Accompanied with the adoption of the new refrigerant, the refrigeration machine oil has also been changed. Therefore, during installation work, be sure that water, dust, former refrigerant, or refrigeration machine oil does not enter the new type refrigerant R410A air conditioner circuit.

To prevent mixing of refrigerant or refrigerating machine oil, the sizes of connecting sections of charging port on main unit and installation tools are different from those of the conventional refrigerant units. Accordingly, special tools are required for the new refrigerant (R410A) units as shown on page 5. For connecting pipes, use new and clean piping materials with high pressure fittings made for R410A only, so that water and/or dust does not enter. Moreover, do not use the existing piping because there are some problems with pressure fittings and possible impurities in existing piping.

CAUTION

TO DISCONNECT THE APPLIANCE FROM THE MAIN POWER SUPPLY

A switch or circuit breaker that can disconnect all poles must be included in the fixed wiring. Be sure to use an approved circuit breaker or switch.

DANGER

- FOR USE BY QUALIFIED PERSONS ONLY.
- TURN OFF MAIN POWER SUPPLY BEFORE ATTEMPTING ANY ELECTRICAL WORK. MAKE SURE ALL POWER SWITCHES ARE OFF. FAILURE TO DO SO MAY CAUSE ELECTRIC SHOCK.
- CORRECTLY CONNECT THE CONNECTING CABLE. IF THE CONNECTING CABLE IS INCORRECTLY CONNECTED, ELECTRIC PARTS MAY BE DAMAGED.
- CHECK THAT THE EARTH WIRE IS NOT BROKEN OR DISCONNECTED BEFORE INSTALLATION. FAILURE TO DO SO MAY CAUSE ELECTRIC SHOCK.
- DO NOT INSTALL THE UNIT IN A PLACE WHERE INFLAMMABLE GAS CAN LEAK. A FIRE CAN RESULT IF INFLAMMABLE GAS ACCUMULATES AROUND THE UNIT.
- TO PREVENT THE INDOOR UNIT FROM OVERHEATING AND CAUSING A FIRE HAZARD, PLACE THE UNIT WELL AWAY (MORE THAN 2 M) FROM HEAT SOURCES SUCH AS RADIATORS, HEAT REGISTORS, FURNACE, STOVES, ETC.
- WHEN MOVING THE AIR-CONDITIONER FOR INSTALLATION TO ANOTHER PLACE, BE VERY CAREFUL NOT TO ALLOW THE SPECIFIED REFRIGERANT (R410A) TO BECOME MIXED WITH ANY OTHER GASEOUS BODY INTO THE REFRIGERATION CIRCUIT. IF AIR OR ANY OTHER GAS MIXES WITH THE REFRIGERANT, THE GAS PRESSURE IN THE REFRIGERATION CIRCUIT WILL BECOME ABNORMALLY HIGH AND IT MAY RESULT IN THE PIPE BURSTING OR PERSONNEL INJURIES.
- IN THE EVENT THAT THE REFRIGERANT GAS LEAKS OUT OF THE PIPE DURING THE INSTALLATION WORK, IMMEDIATELY LET FRESH AIR INTO THE ROOM. IF THE REFRIGERANT GAS IS HEATED, POISONOUS GAS MAY RESULT.
- WHEN INSTALLING THE AIR CONDITIONER UNIT, MAKE SURE THAT THE REFRIGERANT PIPE IS CONNECTED SECURELY BEFORE THE COMPRESSOR IS OPERATED. IF THE COMPRESSOR IS OPERATED WITH THE REFRIGERANT PIPE UNCONNECTED, WHICH MEANS THAT THE SERVICE VALVE WILL BE LEFT OPEN, AIR, ETC. WILL BE SUCKED IN, CAUSING THE PRESSURE INSIDE THE REFRIGERATION CYCLE TO RISE TO AN ABNORMALLY HIGH LEVEL, AND POSSIBLY RESULTING IN RUPTURE, INJURY, ETC.
- WHEN CARRYING OUT THE PUMP-DOWN WORK, SHUT DOWN THE COMPRESSOR BEFORE DISCONNECTING THE REFRIGERANT PIPE. DISCONNECTING THE REFRIGERANT PIPE WITH THE SERVICE VALVE LEFT OPEN AND WITH THE COMPRESSOR STILL OPERATING WILL CAUSE AIR, ETC. TO BE SUCKED IN, RAISING THE PRESSURE INSIDE THE REFRIGERATION CYCLE TO AN ABNORMALLY HIGH LEVEL, AND POSSIBLY RESULTING IN RUPTURING, INJURY, ETC.

WARNING

- Never modify this unit by removing any of the safety guards.
- The installation of the air conditioner must be positioned in a location that can sufficiently support its weight. Failure to do so may result in unit damage and human injury.
- Appliance shall be installed in accordance with national wiring regulations.
- If you detect any damage, do not install the unit. Contact your Toshiba dealer immediately.

CAUTION

- Exposure of unit to water or other moisture before installation may result in an electrical short. Do not store in a wet basement or expose to rain or water.
- After unpacking the unit, examine it carefully for any damage.
- Do not install in a place that can increase the vibration of the unit. Do not install in a place that can amplify the noise level of the unit or where noise or discharged air might disturb neighbors.
- To avoid personal injury, be careful when handling parts with sharp edges.
- Please read this installation manual carefully before installing the unit. It contains further important instructions necessary for proper installation.
- Wear work gloves when carrying out the installation work or repairs. Contact with parts, etc. may cause injury if the work or repairs are conducted without wearing gloves.

2 INSTALLATION DIAGRAM OF INDOOR AND OUTDOOR UNITS

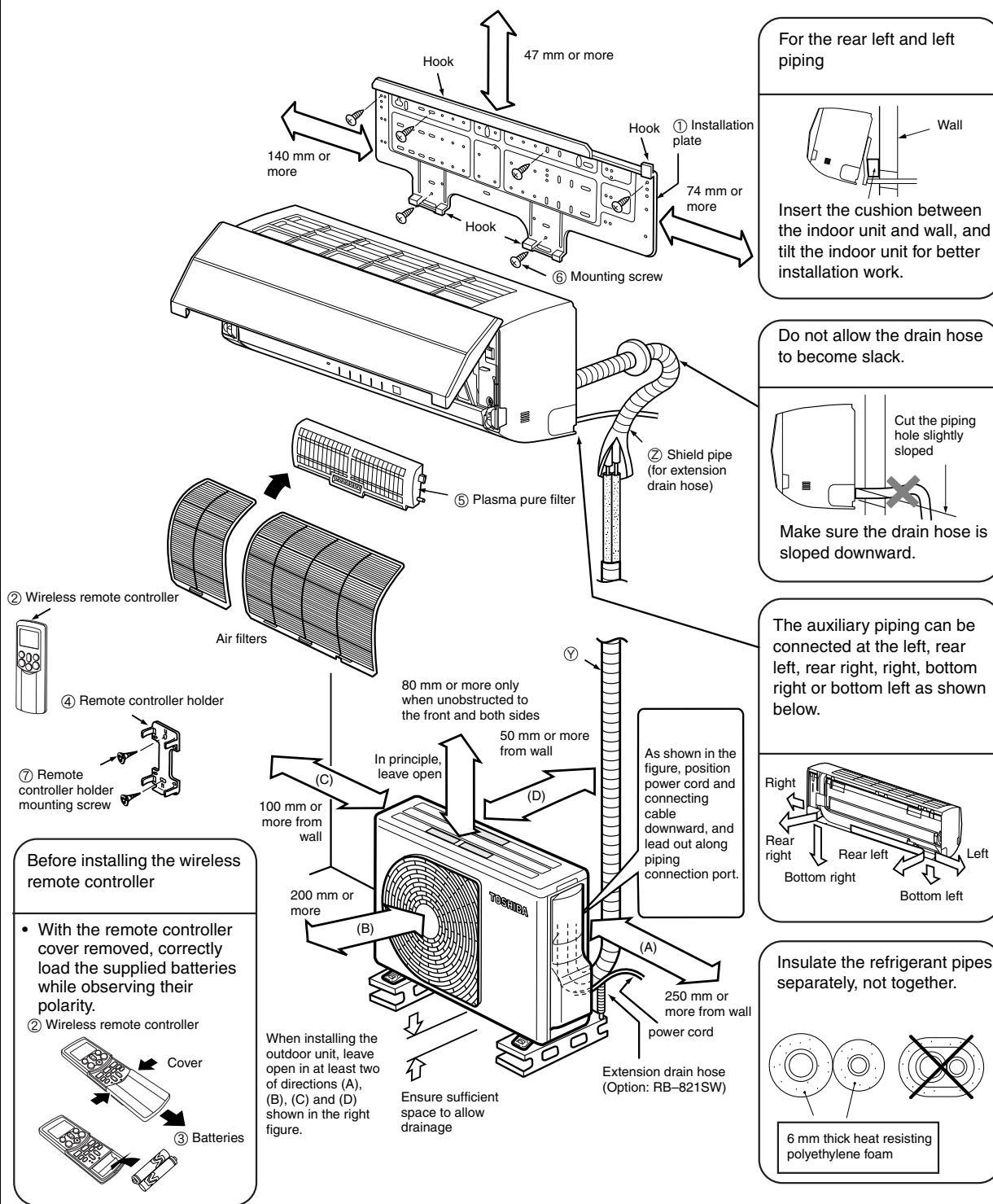

When using a multi-system outdoor unit, refer to the installation manual provided with the model concerned.

3 OPTIONAL PARTS, ACCESORIES AND TOOLS

Optional Installation Parts





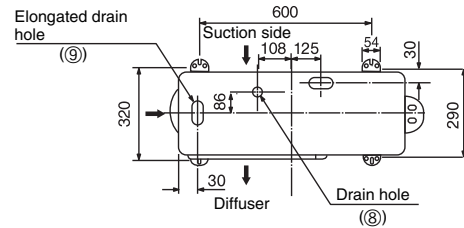

Part Code	Parts name	Q'ty		
①	Refrigerant piping	1 ea.		
	Indoor unit name		Liquid side (Outer diameter)	Gas side (Outer diameter)
	RAS-B10SKVP-E, B13SKVP-E RAS-M10SKCVP-E, M13SKCVP-E		6.35 mm	9.52 mm
	RAS-B16SKVP-E, M16SKCVP-E		6.35 mm	12.7 mm
②	Shield pipe (for extension drain hose) (polyethylene foam, 6 mm thick)	1		

Attachment bolt arrangement of outdoor unit

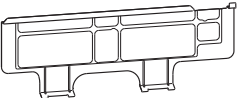
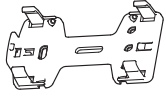
- Secure the outdoor unit with the attachment bolts and nuts if the unit is likely to be exposed to a strong wind.
- Use $\phi 8$ mm or $\phi 10$ mm anchor bolts and nuts.
- If it is necessary to drain the defrost water, attach drain nipple to the base plate of the outdoor unit before installing it.

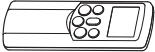
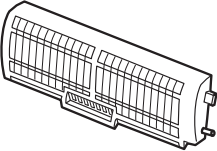

Accessory and Installation Parts

Part No.	Part name (Q'ty)	Part No.	Part name (Q'ty)	Part No.	Part name (Q'ty)
①	 Installation plate x 1	④	 Remote controller holder x 1	⑦	 Remote controller holder mounting screw $\phi 3.1 \times 16L \times 2$
②	 Wireless remote controller x 1	⑤	 Plasma pure filter x 1	⑧	 Drain nipple* x 1 (RAS-10SAVP-E, 13SAVP-E, 16SAVP-E)
③	 Battery x 2	⑥	 Mounting screw $\phi 4 \times 25L \times 6$	⑨	 Water-proof rubber cap* x 2 (RAS-10SAVP-E, 13SAVP-E, 16SAVP-E)

Others

Name
Owner's manual
Installation manual
Important information and warning*
B/W strips (Energy efficiency labels)

This model is not equipped with an extension drain hose.

Option:

For the extension drain hose, use the optionally available RB-821SW or a commercially available one.

Parts marked with asterisk (*) are packaged with the outdoor unit.

When using a multi-system outdoor unit, refer to the installation manual provided with the model concerned.







Installation/Service Tools

Changes in the product and components

On air conditioners using R410A, in order to prevent any other refrigerant from being accidentally charged, the service port diameter size of the outdoor unit control valve (3 way valve) has been changed. (1/2 UNF 20 threads per inch)

- In order to increase the pressure resisting strength of the refrigerant piping, flare processing diameter and opposing flare nuts sizes have been changed. (for copper pipes with nominal dimensions 1/2 and 5/8)

New tools for R410A

New tools for R410A	Applicable to R22 model		Changes
Gauge manifold	×		As the working pressure is high, it is impossible to measure the working pressure using conventional gauges. In order to prevent any other refrigerant from being charged, the port diameters have been changed.
Charge hose	×		In order to increase pressure resisting strength, hose materials and port sizes have been changed (to 1/2 UNF 20 threads per inch). When purchasing a charge hose, be sure to confirm the port size.
Electronic balance for refrigerant charging	○		As working pressure is high and gasification speed is fast, it is difficult to read the indicated value by means of charging cylinder, as air bubbles occur.
Torque wrench (nominal dia. 1/2, 5/8)	×		The size of opposing flare nuts have been increased. Incidentally, a common wrench is used for nominal diameters 1/4 and 3/8.
Flare tool (clutch type)	○		By increasing the clamp bar's receiving hole size, strength of spring in the tool has been improved.
Gauge for projection adjustment	—		Used when flare is made by using conventional flare tool.
Vacuum pump adapter	○		Connected to conventional vacuum pump. It is necessary to use an adapter to prevent vacuum pump oil from flowing back into the charge hose. The charge hose connecting part has two ports — one is for conventional refrigerant (7/16 UNF 20 threads per inch) and the other is for R410A. If the vacuum pump oil (mineral) mixes with R410A, a sludge may occur and damage the equipment.
Gas leakage detector	×		Exclusive for HFC refrigerant.

- Incidentally, the "refrigerant cylinder" comes with the refrigerant designation (R410A) and protector coating in the U.S.'s ARI specified rose color (ARI color code: PMS 507).
- Also, the "charge port and packing for refrigerant cylinder" requires 1/2 UNF 20 threads per inch corresponding to the charge hose's port size.

4 INSTALLATION OF INDOOR UNIT

Installation Location

- A place which provides enough space around the indoor unit as shown in the diagram. (☞ see page 3.)
- A place where there are no obstacles near the air inlet and outlet.
- A place which allows easy installation of the piping to the outdoor unit.
- A place which allows the front panel to be opened.
- The indoor unit shall be installed so that the top of the indoor unit is positioned at least 2 m high. Also, avoid putting anything on the top of the indoor unit.

CAUTION

- Direct sunlight on the indoor unit wireless receiver should be avoided.
- The microprocessor in the indoor unit should not be too close to r-f sources.
(For details, see the owner's manual.)

Remote controller

- Should be placed where there are no obstacles, such as curtains, that may block the signal.
- Do not install the remote controller in a place exposed to direct sunlight or close to a heating source, such as a stove.
- Keep the remote controller at least 1 m away from the nearest TV set or stereo equipment. (This is necessary to prevent image disturbance or noise interference.)
- The location of the remote controller should be determined as shown below.

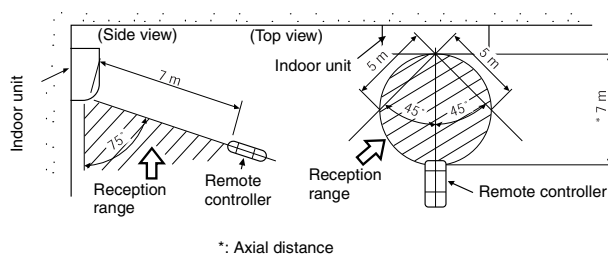

Drilling and Mounting Installation Plate

Drilling

When installing the refrigerant pipes from the rear.

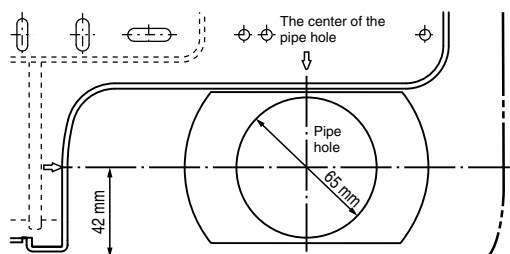

1. Decide the installation plate mounting position on the wall.
2. Mark the corresponding pipe hole wall positions according to the positioning marks (⇔) on the installation plate.
3. Drill the pipe holes ($\phi 65$ mm) slightly slanted downward to the outside.

NOTE

- When drilling into a wall that contains a metal lath, wire lath or metal plate, be sure to use a pipe hole brim ring sold separately.

Mounting the installation plate

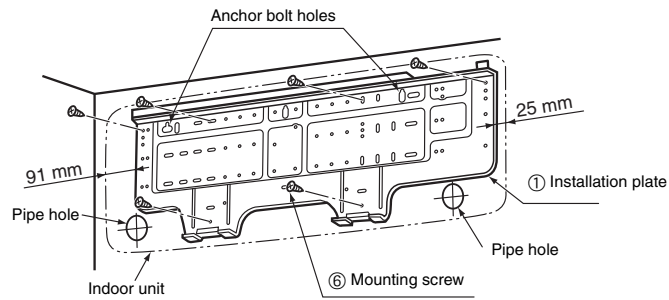

When the installation plate is directly mounted on the wall

1. Securely fit the installation plate onto the wall by screws with the upper and lower catches.
2. To mount the installation plate on a concrete wall use anchor bolts. Drill the anchor bolt holes as illustrated in the above figure.
3. Place the level at the top end of the installation plate, and check that the plate is horizontal.

CAUTION

When installing the installation plate with mounting screws, do not use anchor bolt holes. Otherwise the unit may fall down and result in personal injury and property damage.

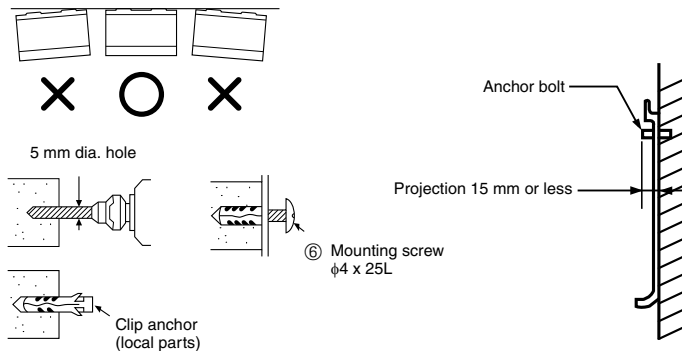

CAUTION

Failure to securely install the unit may result in personal injury and/or property damage if the unit falls.

- In case of block, brick, concrete or similar type walls, drill 5 mm dia. holes in the wall.
- Insert clip anchors for the ⑥ mounting screws.

NOTE

- Install the installation plate using between 4 to 6 mounting screws, making sure all four corners are secure.

Electrical Work

1. The supply voltage must be the same as the rated voltage of the air conditioner.
2. Prepare a power source for the exclusive use of the air conditioner.

NOTE

- Wire type: H07RN-F or 60245IEC66 (1.0 mm²)

CAUTION

A switch or circuit breaker that can disconnect all poles must be included in the fixed wiring. Be sure to use an approved circuit breaker or switch.

NOTE

- Make sure the wire length is sufficient before performing wiring work.

Wiring Connection

How to connect the connecting cable

Wiring the connecting cable can be carried out without removing the front panel.

1. Remove the air inlet grille. Open the air inlet grille upward and pull it toward you.
2. Remove the terminal cover and cord clamp.
3. Insert the connecting cable (or as according to local regulations/codes) into the pipe hole on the wall.
4. Pull the connecting cable through the cable slot on the rear panel so that it protrudes about 15 cm out of the front.
5. Insert the connecting cable fully into the terminal block and secure it tightly with screws. Make a loop with the earth wire under the terminal block and secure it with the earth screw.
6. Tightening torque: 1.2 N·m (0.12 kgf·m)
7. Secure the connecting cable with the cord clamp.
8. Attach the terminal cover, rear plate bushing and air inlet grille on the indoor unit.

CAUTION

- Be sure to refer to the wiring system diagram labeled inside the front panel.
- Check local electrical regulations for any specific wiring instructions or limitations.

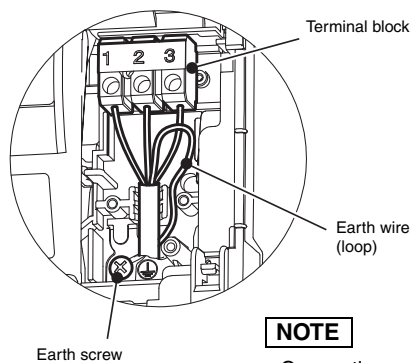
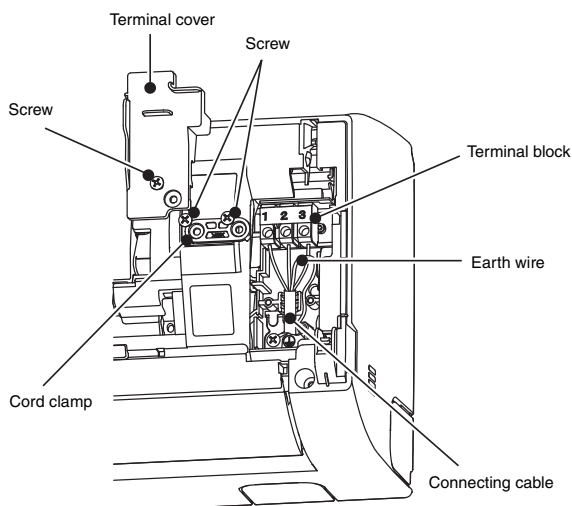

NOTE

- Connecting cable (Indoor unit/outdoor unit)
- Wire type: H07RN-F or 60245IEC66 (1.0 mm²)

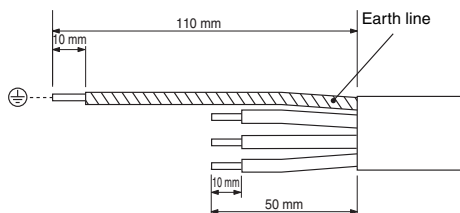
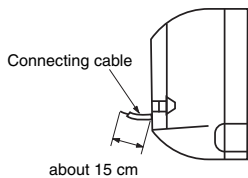

Piping and Drain Hose Installation

Piping and drain hose forming

- Since condensation results in machine trouble, make sure to insulate both the connecting pipes separately. (Use polyethylene foam as insulating material.)

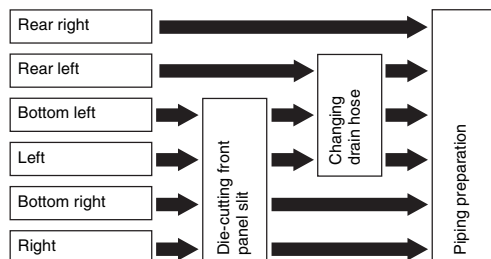

1. Die-cutting front panel slit

Cut out the slit on the left or right side of the front panel for the left or right connection and the slit on the bottom left or right side of the front panel for the bottom left or right connection with a pair of nippers.

2. Changing drain hose

For left connection, left-bottom connection and rear-left connection's piping, it is necessary to relocate the drain hose and drain cap.

• How to remove the drain cap

Clamp drain cap with needle-nose pliers, and pull out.

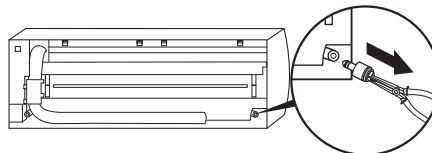

• How to remove the drain hose

The drain hose is secured in place by a screw.

Remove the screw securing the drain hose, then pull out the drain hose.

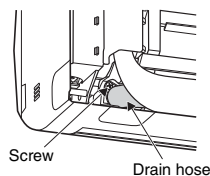

• How to attach the drain cap

1. Insert hexagonal wrench (4 mm).

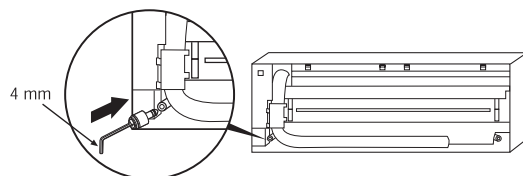

2. Firmly insert drain cap.

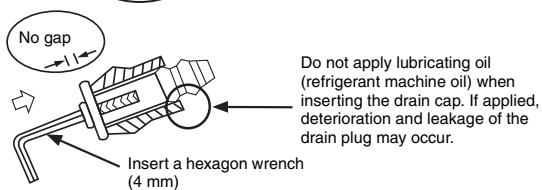

• How to attach the drain hose

Always use the original screw that secured the drain hose to the unit. Using a different screw may cause water to leak.

Insert the drain hose firmly until the connector contacts the insulation, then secure it in place using the original screw.

CAUTION

Securely insert the drain hose and drain cap; otherwise, water may leak.

In case of right or left piping

- After making slits on the front panel with a knife or similar tool, cut them out with a pair of nippers or an equivalent tool.

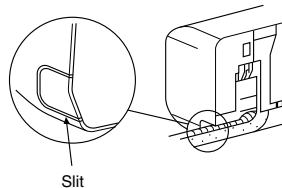

In case of bottom right or bottom left piping

- After making slits on the front panel with a knife or similar tool, cut them out with a pair of nippers or an equivalent tool.

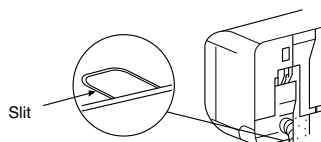

Left-hand connection with piping

Bend the connecting pipes so that they are positioned within 43 mm above the wall surface. If the connecting pipes are positioned more than 43 mm above the wall surface, the indoor unit may be unstable. When bending the connecting pipe, make sure to use a spring bender to avoid crushing the pipe.

Refer to the table below for the bending radius of each connection pipe.

Outer diameter	Bending radius
6.35 mm	30 mm
9.52 mm	40 mm
12.7 mm	50 mm

To connect the pipe after installation of the unit (figure)

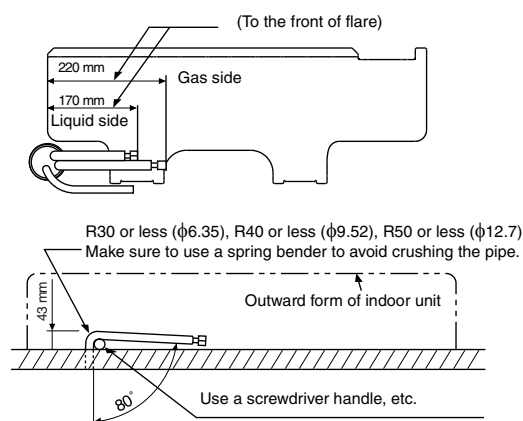

NOTE

If the pipe is incorrectly bent, the indoor unit may be unstable on the wall.

After passing the connecting pipe through the pipe hole, connect the connecting pipe to the auxiliary pipes and wrap the facing tape around them.

CAUTION

- Bind the auxiliary pipes (two) and connecting cable with facing tape tightly. In case of leftward piping and rear-leftward piping, bind the auxiliary pipes (two) only with facing tape.

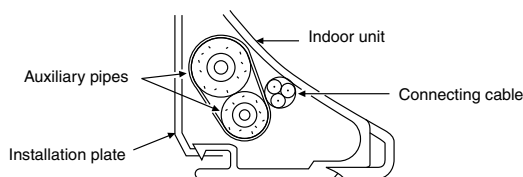

- Carefully arrange the pipes so that none of the pipes stick out of the rear plate of the indoor unit.
- Carefully connect the auxiliary pipes and connecting pipes to each other and cut off the insulating tape wound on the connecting pipe to avoid double-taping at the joint, moreover, seal the joint with the vinyl tape, etc.
- Since condensation can result in machine performance trouble, be sure to insulate both connecting pipes. (Use polyethylene foam as insulating material.)
- When bending a pipe, be careful not to crush it.

Indoor Unit Installation

1. Pass the pipe through the hole in the wall, and hook the indoor unit on the installation plate at the upper hooks.
2. Swing the indoor unit to right and left to confirm that it is firmly hooked on the installation plate.
3. While pressing the indoor unit onto the wall, hook it at the lower part on the installation plate. Pull the indoor unit toward you to confirm that it is firmly hooked on the installation plate.

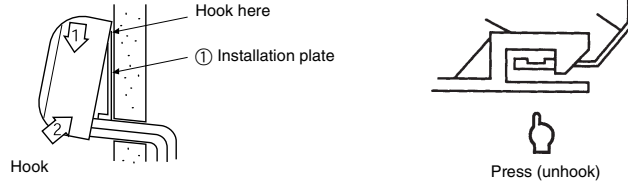

- For detaching the indoor unit from the installation plate pull the indoor unit toward you while pushing the bottom up at the specified places.

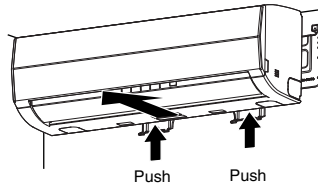

Drainage

1. Run the drain hose at a downward sloped angle.

NOTE

- Hole should be made at a slight downward slant on the outdoor side.

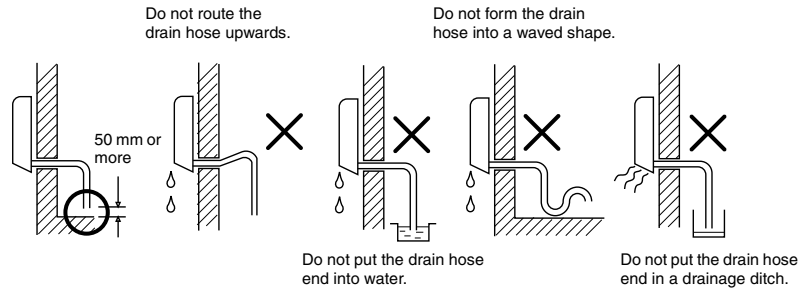

2. Put water in the drain pan and make sure that the water is being drained outside.
3. When connecting extension drain hose, insulate the connection part of extension drain hose with shield pipe.

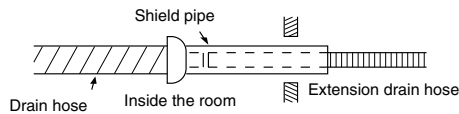

CAUTION

Install the drain pipe for proper drainage. Improper drainage can result in water dripping inside the room.

This air conditioner has been designed to drain water collected from condensation which forms on the back of the indoor unit, to the drain pan. Therefore, do not locate the power cord and other parts at a height above the drain guide.

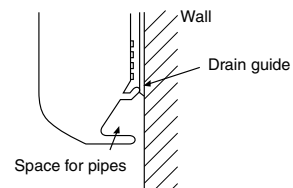

5 INSTALLATION OF OUTDOOR UNIT

Installation Location

- A place which provides enough space around the outdoor unit as shown in the diagram.
- A place which can bear the weight of the outdoor unit and does not allow an increase in noise level and vibration.
- A place where the operation noise and discharged air do not disturb neighbors.
- A place which is not exposed to a strong wind.
- A place free of combustible gases.
- A place which does not block a passageway.
- When the outdoor unit is to be installed in an elevated position, be sure to secure its feet.
- This air conditioner accepts a connection piping length from 2 m to 25 m.
 - There is no need to add refrigerant as long as the length of the connection piping is 15 m or less.
 - You will need to add 20 g of refrigerant per meter of added connection piping for installations requiring connection piping to be between 16 m to 25 m.
- An allowable height level is up to 10 m.
- A place where the drain water does not cause any problems.

Precautions for Adding Refrigerant

- Use a scale having at least 10 g per index line precision when adding the refrigerant. Do not use a bathroom scale or similar instrument.
- Use liquid refrigerant when refilling the refrigerant. Since the refrigerant is in liquid form, it can fill quickly. Therefore, perform the filling operation carefully and insert the refrigerant gradually.

CAUTION

1. Install the outdoor unit in a location where there are no obstructions near its air intake or air outlet.
2. When the outdoor unit is installed in a place that is always exposed to strong winds like on the coast or on a high story of a building, secure the normal fan operation using a duct or a wind shield.
3. Especially in windy areas, install the unit to prevent the admission of wind.
4. Installation in the following places may result in trouble. Do not install the unit in such places.
 - A place full of machine oil.
 - A saline-place such as the coast.
 - A place full of sulfide gas.
 - A place where high-frequency waves are likely to be generated, such as from audio equipment, welders, and medical equipment.

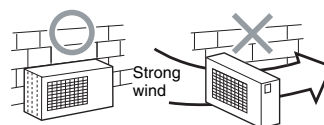

Draining the water

- Holes are provided on the base plate of the outdoor unit to ensure that the defrost water produced during heating operations is drained off efficiently. If a centralized drain is required when installing the unit on a balcony or wall, follow the steps below to drain off the water.
1. Proceed with water-proofing by installing the water-proof rubber caps ⑨ in the 2 elongated holes on the base plate of the outdoor unit.
[How to install the water-proof rubber caps]
 - 1) Place four fingers into each cap, and insert the caps into the water drain holes by pushing them into place from the underside of the base plate.
 - 2) Press down on the outer circumferences of the caps to ensure that they have been inserted tightly.
(Water leaks may result if the caps have not been inserted properly, if their outer circumferences lift up or the caps catch on or wedge against something.)
 2. Install the drain nipple ⑧ and a commercially available drain hose (with 16 mm inside diameter), and drain off the water.
(For the position where the drain nipple ⑧ is installed, refer to the installation diagram of the indoor and outdoor units.)
- Check that the outdoor unit is horizontal, and route the drain hose at a downward sloped angle with very little slack to the hose.

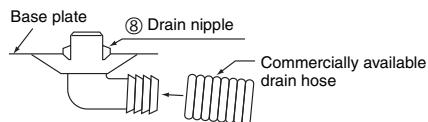
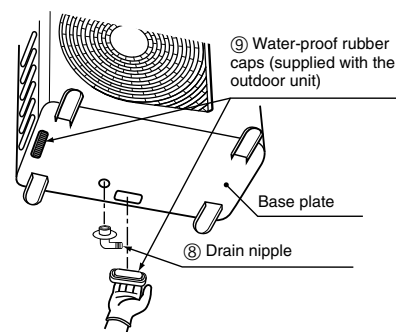

Do not use ordinary garden hose, which can flatten and prevent drainage.

Refrigerant Piping Connection

Flaring

- Cut the pipe with a pipe cutter.

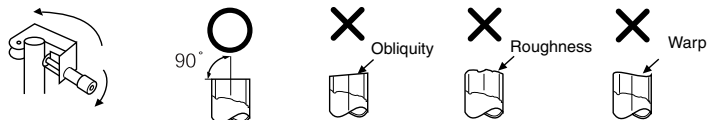

- Insert a flare nut into the pipe, and flare the pipe.

- Projection margin in flaring: A (Unit: mm)

Rigid (Clutch type)

Outer diameter of copper pipe	R410A tool used	Conventional tool used
6.35	0 to 0.5	1.0 to 1.5
9.52	0 to 0.5	1.0 to 1.5
12.7	0 to 0.5	1.0 to 1.5

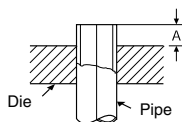

Imperial (Wing nut type)

Outer diameter of copper pipe	R410A
6.35	1.5 to 2.0
9.52	1.5 to 2.0
12.7	2.0 to 2.5

- Flaring size : B (Unit : mm)

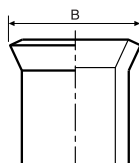

Outer diameter of copper pipe	B ⁺⁰ _{-0.4}	
	R410A	R22
6.35	9.1	9.0
9.52	13.2	13.0
12.7	16.6	16.2

- In case of flaring for R410A with the conventional flare tool, pull it out approx. 0.5 mm more than that of R22 to adjust the specified flare size. The copper pipe gauge is useful for adjusting projection margin size.

Tighten the connection

Align the centers of the connecting pipes and tighten the flare nut as much as possible with your fingers. Then tighten the nut with a wrench and torque wrench as shown in the figure.

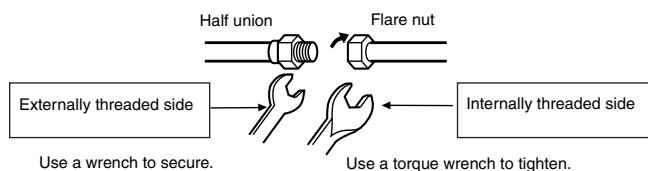

CAUTION

- Do not apply excessive force. Otherwise, the nut may break.

Outer diameter of copper pipe	Tightening torque (Unit: N·m)
φ6.35 mm	14 to 18 (1.4 to 1.8 kgf·m)
φ9.52 mm	33 to 42 (3.3 to 4.2 kgf·m)
φ12.7 mm	50 to 62 (5.0 to 6.2 kgf·m)

- Tightening torque for connection of flare pipe
The pressure of R410A is higher than R22. (Approx. 1.6 times.) Therefore securely tighten the flare pipes which connect the outdoor unit and the indoor unit with the specified tightening torque using a torque wrench.
If any flare pipe is incorrectly connected, it may cause not only a gas leakage but also trouble in the refrigeration cycle.

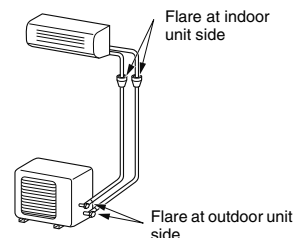

Evacuating

After the piping has been connected to the indoor unit, perform the air purge.

AIR PURGE

Evacuate the air in the connecting pipes and in the indoor unit using a vacuum pump. Do not use the refrigerant in the outdoor unit. For details, see the vacuum pump manual.

Use a vacuum pump

Be sure to use a vacuum pump with counter-flow prevention function so that oil inside the pump does not flow back into the air conditioner pipes when the pump stops. (If oil inside the vacuum pump enters the air conditioner circuit which uses R410A, trouble with the refrigeration system may develop.)

1. Connect the charge hose from the manifold valve to the service port of the gas side packed valve.
2. Connect the charge hose to the port of the vacuum pump.
3. Open fully the low pressure side handle of the gauge manifold valve.
4. Operate the vacuum pump to begin evacuating. Perform evacuating for about 15 minutes if the piping length is 20 meters (15 minutes for 20 meters) (assuming a pump capacity of 27 liters per minute). Confirm that the compound pressure gauge reading is -101 kPa (-76 cmHg).
5. Close the low pressure valve handle of gauge manifold.
6. Open fully the valve stem of the packed valves (both sides of Gas and Liquid).
7. Remove the charging hose from the service port.
8. Securely tighten the caps on the packed valves.

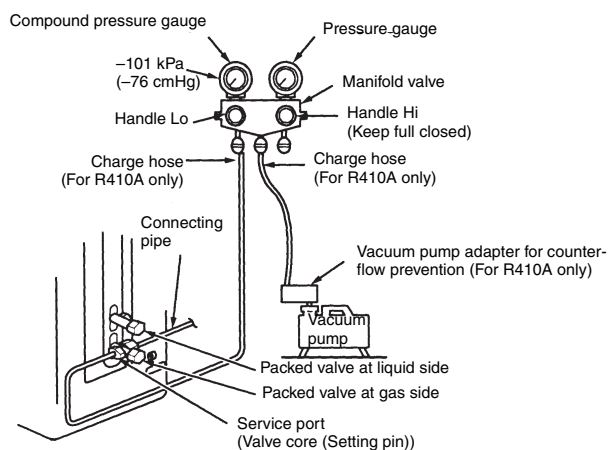

CAUTION

• IMPORTANT POINTS FOR PIPING WORK

- (1) Prevent dust and moisture from entering the pipes.
- (2) Tighten connections carefully (between pipes and unit).
- (3) Evacuate the air in the connecting pipes using a VACUUM PUMP.
- (4) Check for gas leaks at all connections.

Packed valve handling precautions

- Open the valve stem until it touches the stopper. Once it is in contact with the stopper, refrain from applying any more force than is necessary.
- Securely tighten the valve stem cap with torque in the following table:

Gas side (ϕ 12.7 mm)	50 to 62 N·m (5.0 to 6.2 kgf·m)
Gas side (ϕ 9.52 mm)	33 to 42 N·m (3.3 to 4.2 kgf·m)
Liquid side (ϕ 6.35 mm)	14 to 18 N·m (1.4 to 1.8 kgf·m)
Service port	14 to 18 N·m (1.4 to 1.8 kgf·m)

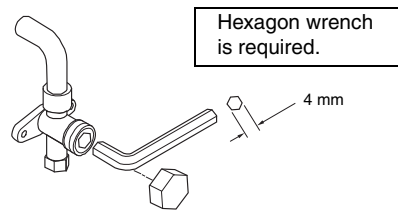
**Wiring Connection**

1. Remove the valve cover, the electric parts cover and the cord clamp from the outdoor unit.
2. Connect the connecting cable to the terminal as identified by the matching numbers on the terminal block of indoor and outdoor unit.
3. Insert the power cord and the connecting cable fully into the terminal block and secure it tightly with screws.
4. Use vinyl tape, etc. to insulate the cords which are not going to be used. Locate them so that they do not touch any electrical or metal parts.
5. Secure the power cord and the connecting cable with the cord clamp.
6. Attach the electric parts cover and the valve cover on the outdoor unit.

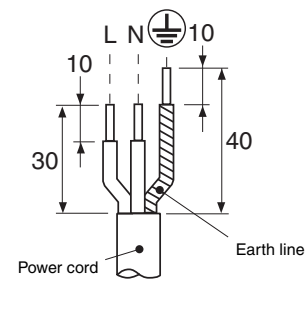
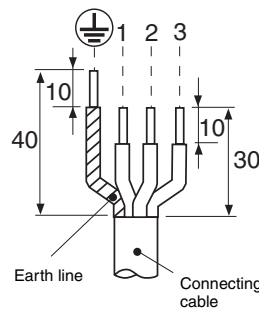
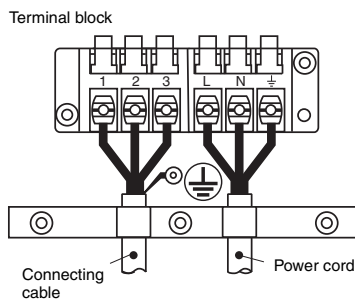
Stripping length of connecting cable

Model	RAS-10SAVP-E	RAS-13SAVP-E	RAS-16SAVP-E
Power source	220–240 V ~50 Hz 220 V ~60 Hz		
Maximum running current	12.5 A		
Installation fuse rating	16 A breaker or fuse (all types can be used)		
Power cord	H07RN-F or 60245IEC66 (1.5 mm ²)		
Connecting cable	Wire type: H07RN-F or 60245IEC66 (1.0 mm ²)		

CAUTION

- Incorrect wiring connection may cause electrical parts to burn out.
 - Be sure to comply with local regulations/codes when running the wire from outdoor unit to indoor unit. (Size of wire and wiring method etc.)
 - Every wire must be securely connected.
 - If incorrect or incomplete wiring is carried out, fire or smoke may result.
 - Prepare the power supply for the exclusive use of the air conditioner.
 - This product can be connected to the main breaker.
- Connection to fixed wiring: A switch or circuit breaker that can disconnect all poles must be included in the fixed wiring. Be sure to use an approved circuit breaker or switch.

6 TEST OPERATION

Gas Leak Test

- Check the flare nut connections for gas leaks with a gas leak detector and/or soapy water.

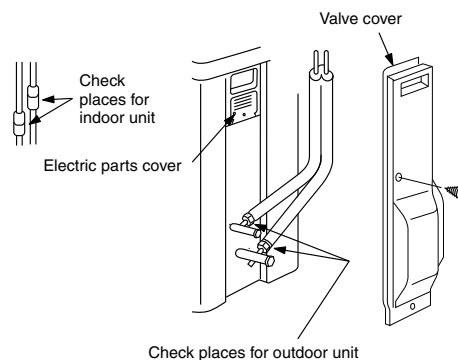

Test Operation

To test the system, press and hold RESET button for 10 sec. (There will be one short beep.)

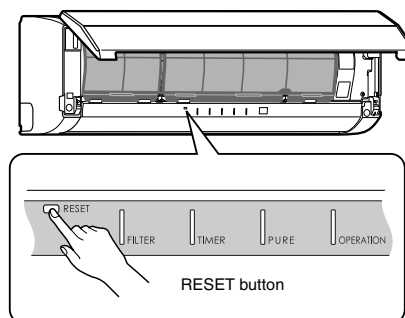

Auto Restart Setting

This product is designed so that, after a power failure, it can restart automatically in the same operating mode as before the power failure.

INFORMATION

The product was shipped with Auto Restart function in the OFF position. Turn it ON as required.

How to set the Auto Restart

- Press and hold the RESET button for about 3 seconds. After 3 seconds, three short electric beeps will be heard to inform you that the Auto Restart has been selected.
- To cancel the Auto Restart, follow the steps described in the section Auto Restart Function of the Owner's Manual.

If the air conditioner operates incorrectly

- If two indoor units are installed in the same room or adjoining rooms, when the user tries to operate only one unit, both units may receive the same remote controller signal and operate. This can be prevented by changing one of the indoor units and remote controllers to setting "B" (the default setting for both units is "A").
- If the indoor unit and remote controller settings are different, the remote controller signal is not accepted.

1. Setting the remote controller

- Slide open the remote controller cover and remove the batteries.
- Cut the jumper wire inside the battery compartment using nippers.
 - The jumper wire should not remain in contact after being cut. Also, be careful not to let plastic scraps, jumper wire cuttings or other debris enter the inside of the remote controller.
- Insert the batteries. "B" appears in the remote controller display.

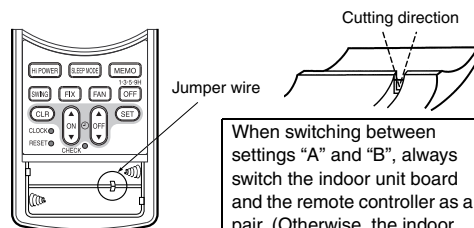

When switching between settings "A" and "B", always switch the indoor unit board and the remote controller as a pair. (Otherwise, the indoor unit will not accept the remote controller's signals.)

2. Setting the unit

Press the RESET button to start automatic operation.

- Press the \odot button of the remote controller that was set in step 1 to stop the air conditioner. (This operation will change the setting to "B".)
- Check that the remote controller operates the indoor unit.

